

# ENGEL

portable fridge-freezers

**A LEGEND IN RELIABILITY**

SR90F  
Built-In



**NOTE:**  
ST90F  
Pictured

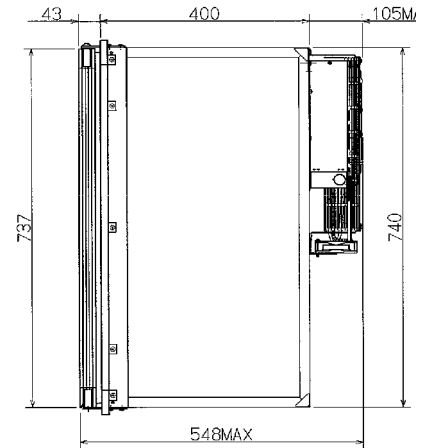
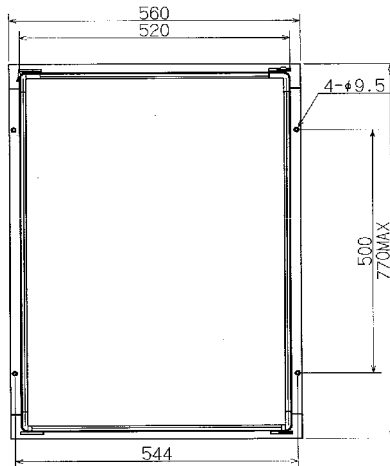
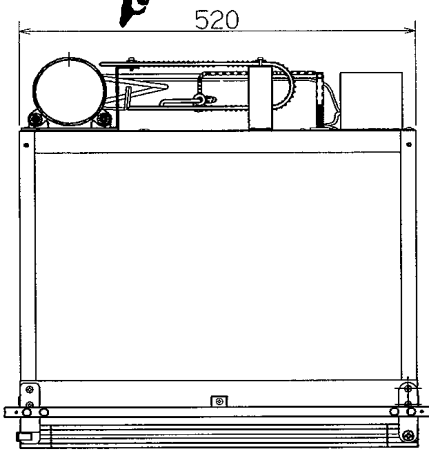

## TECHNICAL SPECIFICATION SHEET

### FEATURES:

100% CFC Free  
Thermostat Controlled  
Energy Efficient Sawafuji Swing Motor  
Low DC Current Draw: 12V 2.5 Amps  
Automatic Voltage Selection AC / DC

Built-in Cabinet Design  
Generator & Solar Panel Compatible  
Strong Construction  
Compact & Lightweight  
Noise Level: 32dB

Polyurethane Insulation  
Turbo Fan  
3 Year Manufacturers Warranty  
Reversible Door - LH / RH

### SPECIFICATIONS:

Storage Volume:	Litres	80 Litres
Overall Dimensions:	H x W x D	770mm x 560mm x 548mm
Installation Dimensions:	H x W x D	747mm x 527mm x 491mm
Materials:		
Cabinet:		
Mounting Frame:	Painted Steel Plate	
Outer Enclosure:	Polyethylene Film	
Inner Case:	High Impact Polystyrene	
Insulation:	Polyurethane Foam	
Door:		
Door Panel:	Steel Plate	
Door Frame:	Polypropylene & Polyvinyl Chloride	
Door Liner:	Polypropylene	
Insulation:	Polyurethane Foam	
Attachments:		
	Ice Cube Tray x 2	
	Shelf x 2	
	Drainage Pan x 1	
	Door Pocket x 2	
Input Voltage:	AC	AC 185 ~ 264V, 50/60Hz
	DC	DC 10.5 ~ 32V
Rated Amperage:	AC	AC 0.35A
	DC	DC 12V 2.5A, 24V 1.3A
Compressor Rating:	AC 13 ~ 16V, 50Hz, 33W	
Refrigerant:	Tetrafluoroethane (R-134a)	
Weight:	24kg	

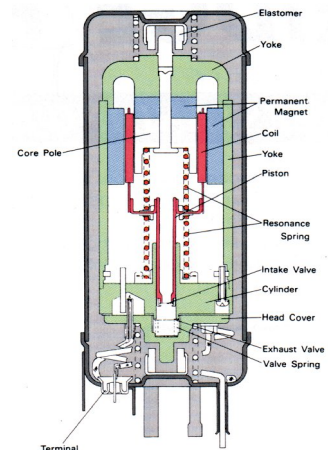

**Sawafuji Swing Motor**