

# ENGEL

portable fridge-freezers

**A LEGEND IN RELIABILITY**



*SR70F  
Built-In*

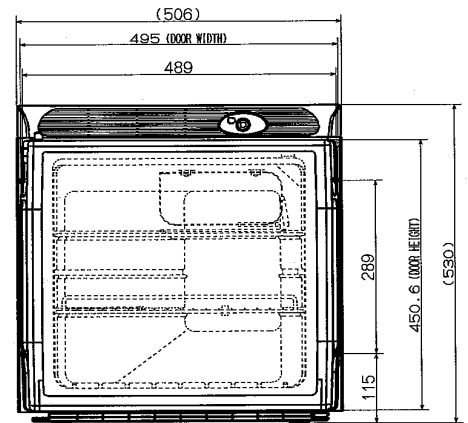
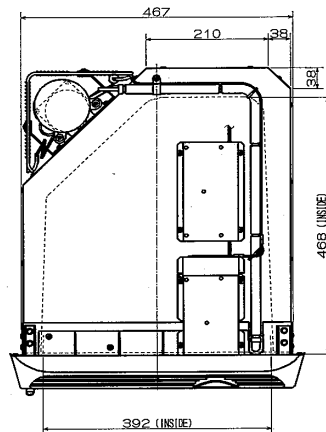
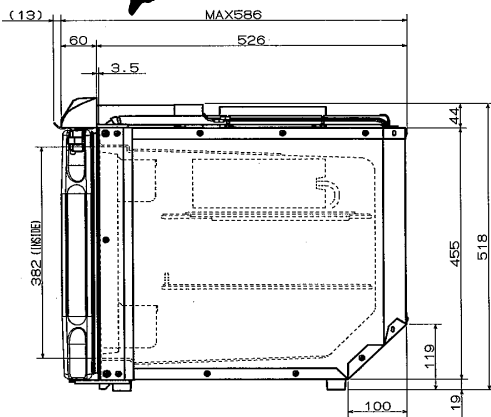

## TECHNICAL SPECIFICATION SHEET

### FEATURES:

100% CFC Free  
Thermostat Controlled  
Energy Efficient Sawafuji Swing Motor  
Low DC Current Draw: 12V 2.5 Amps  
Built-in Cabinet Design

Generator & Solar Panel Compatible  
Strong Construction  
Compact & Lightweight  
Noise Level: 32dB  
Polyurethane Insulation

Turbo Fan  
3 Year Manufacturers Warranty  
Reversible Door - LH / RH

### SPECIFICATIONS:

Storage Volume:	Litres	57 Litres
Overall Dimensions:	H x W x D	530mm x 506mm x 586mm
Installation Dimensions:	H x W x D	518mm x 467mm x 523mm
Materials:		
Cabinet:		
Outer Enclosure:		Galvanised Steel Plate
Inner Case:		High Impact Polystyrene
Insulation:		Polyurethane Foam (HFC-141b)
Door:		
Door Panel:		Steel Plate
Door Frame:		ABS & Polyvinyl Chloride (Gray)
Door Liner:		Polypropylene
Insulation:		Polyurethane Foam (HFC-141b)
Attachments:		
		Ice Cube Tray x 1
		Shelf x 1
		Drainage Pan x 1
		Door Pocket x 2
Input Voltage:	AC	AC 185 ~ 264V, 50/60Hz
	DC	DC 10.5 ~ 32V
Rated Amperage:	AC	AC 0.35A
	DC	DC 12V 2.5A, 24V 1.3A
Compressor Rating:		AC 13 ~ 16V, 50Hz, 33W
Refrigerant:		Tetrafluoroethane (R-134a)
Weight:		22kg

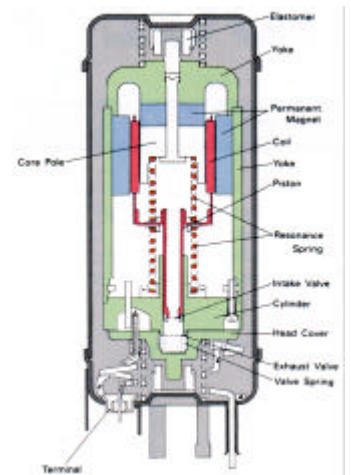

**Sawafuji Swing Motor**